

### KEY FEATURES

- Exceptional power handling: 700 w AES
- 4" (100 mm.) copper voice coil
- High sensitivity: 97 dB
- Superior performance neodymium magnet system
- Half the weight than a conventional ferrite model
- Large Xmax: 8 mm.
- Extra vented magnetic structure
- Designed for subwoofer and woofer applications



### GENERAL DESCRIPTION

This 15" long excursion, lightweight bass loudspeaker has been specifically designed to deliver high impact bass response with an unusual power handling capacity (700 w AES). The magnetic structure incorporates a powerful neodymium magnet, reducing the total mass of the unit to less than 50% of a conventional ferrite model. The power capacity is improved by the use of an copper voice coil (4" diameter) and extra vented magnetic structure.

The 115Nd/W is highly recommended for high demanding subwoofer and woofer applications.

### FREQUENCY RESPONSE AND DISTORTION CURVES

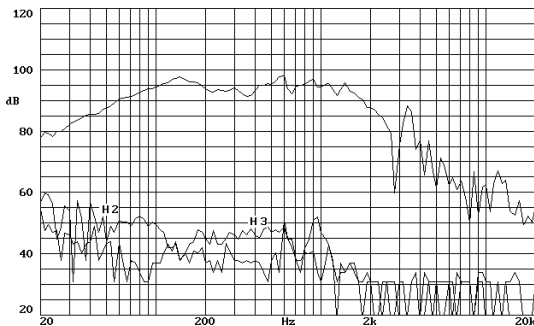

Note: on axis frequency response measured with loudspeaker standing on infinite baffle in anechoic chamber, 1w @ 1m.

### FREE AIR IMPEDANCE CURVE

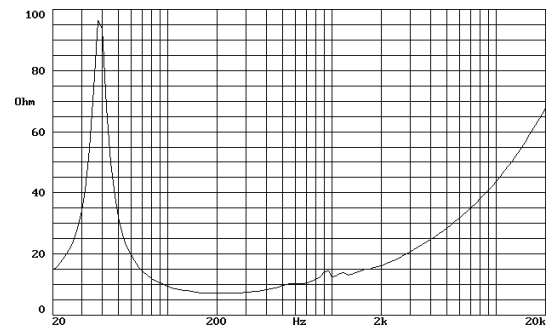

### PREDICTED LOW FREQUENCY RESPONSE

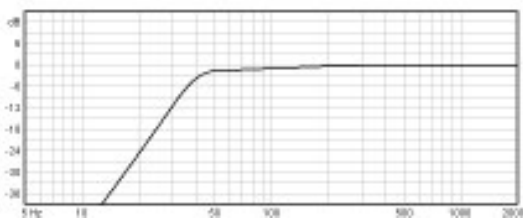

Note: Bass-reflex cabinet, Vb=120 l, fb=40 Hz

### POWER COMPRESSION LOSSES

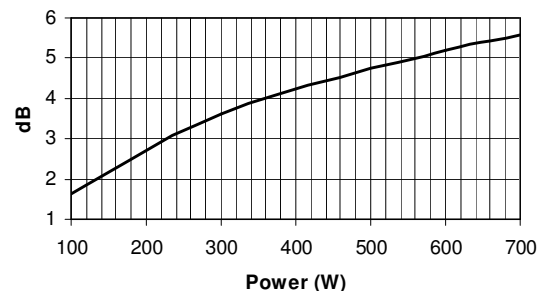

Note: These losses are calculated from a five minutes AES power test applying band limited pink noise (25-1200 Hz). The loudspeaker is free-air standing.

### TECHNICAL SPECIFICATIONS

Nominal diameter	380 mm. 15 in.
Rated impedance	8 ohms.
Minimum impedance	6.5 ohms.
Power capacity *	700 w AES
Program power	1400 w
Sensitivity	97 dB 2.83v @ 1m @ 2π
Frequency range	30 - 2000 Hz
Recom. enclosure vol.	60 / 150 l 2.1 / 5.3 ft. <sup>3</sup>
Voice coil diameter	100 mm. 4 in.
Magnetic assembly weight	4.9 kg. 10.78 lb.
BL factor	22.8 N / A
Moving mass	0.13 kg.
Voice coil length	21 mm.
Air gap height	8 mm.
X damage (peak to peak)	35 mm.

### MOUNTING INFORMATION

Overall diameter	388 mm. 15.28 in.
Bolt circle diameter	370 mm. 14.57 in.
Baffle cutout diameter:	
- Front mount	352 mm. 13.86 in.
- Rear mount	355 mm. 13.98 in.
Depth	150 mm. 5.90 in.
Volume displaced by driver	5 l 0.18 ft. <sup>3</sup>
Net weight	7 kg. 15.4 lb.
Shipping weight	8.2 kg. 18.04 lb.

### THIELE-SMALL PARAMETERS \*\*

Resonant frequency, fs	37 Hz
D.C. Voice coil resistance, Re	6.1 ohms.
Mechanical Quality Factor, Qms	5.6
Electrical Quality Factor, Qes	0.36
Total Quality Factor, Qts	0.34
Equivalent Air Volume to Cms, Vas	150 l
Mechanical Compliance, Cms	130 μm / N
Mechanical Resistance, Rms	5.8 kg / s
Efficiency, ηo (%)	2
Effective Surface Area, Sd (m <sup>2</sup> )	0.0910 m <sup>2</sup>
Maximum Displacement, Xmax	8 mm.
Displacement Volume, Vd	730 cm <sup>3</sup>
Voice Coil Inductance, Le @ 1 kHz	1.1 mH

### DIMENSION DRAWINGS

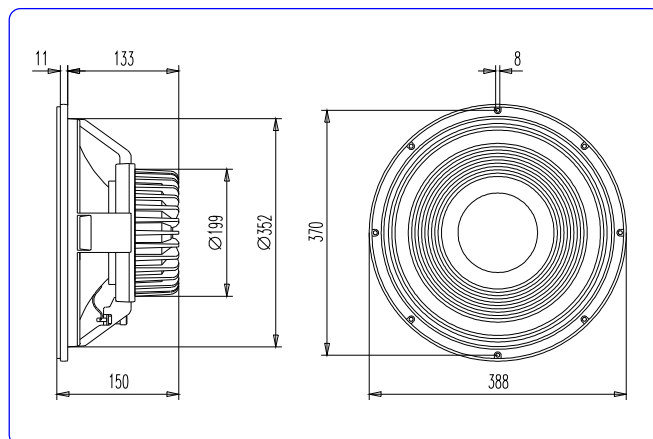

### MATERIALS

- **Voice coil:** copper wire with high temperature bonding strength. Polyimide fiber glass former able to withstand high temperatures.
- **Cone:** high stiffness paper cone.
- **Surround:** treated cloth to assure good retaining of elasticity in despite of continuing use.
- **Spider:** nomex spider, it maintains good mechanical properties at high applied power.
- **Metal parts:** anti-corrosion coated parts designed to resist aggressive environmental conditions.
- **Basket:** specially designed die cast aluminium basket to avoid disturbing resonances.
- **Magnet:** high energy neodymium magnet.

#### Notes:

\*The power capacity is determined according to AES2-1984 (r2003) standard. Program power is defined as the transducer's ability to handle normal music program material.

\*\*T-S parameters are measured after an exercise period using a preconditioning power test. The measurements are carried out with a velocity-current laser transducer and will reflect the long term parameters (once the loudspeaker has been working for a short period of time).



acústica beyma, s.a.